

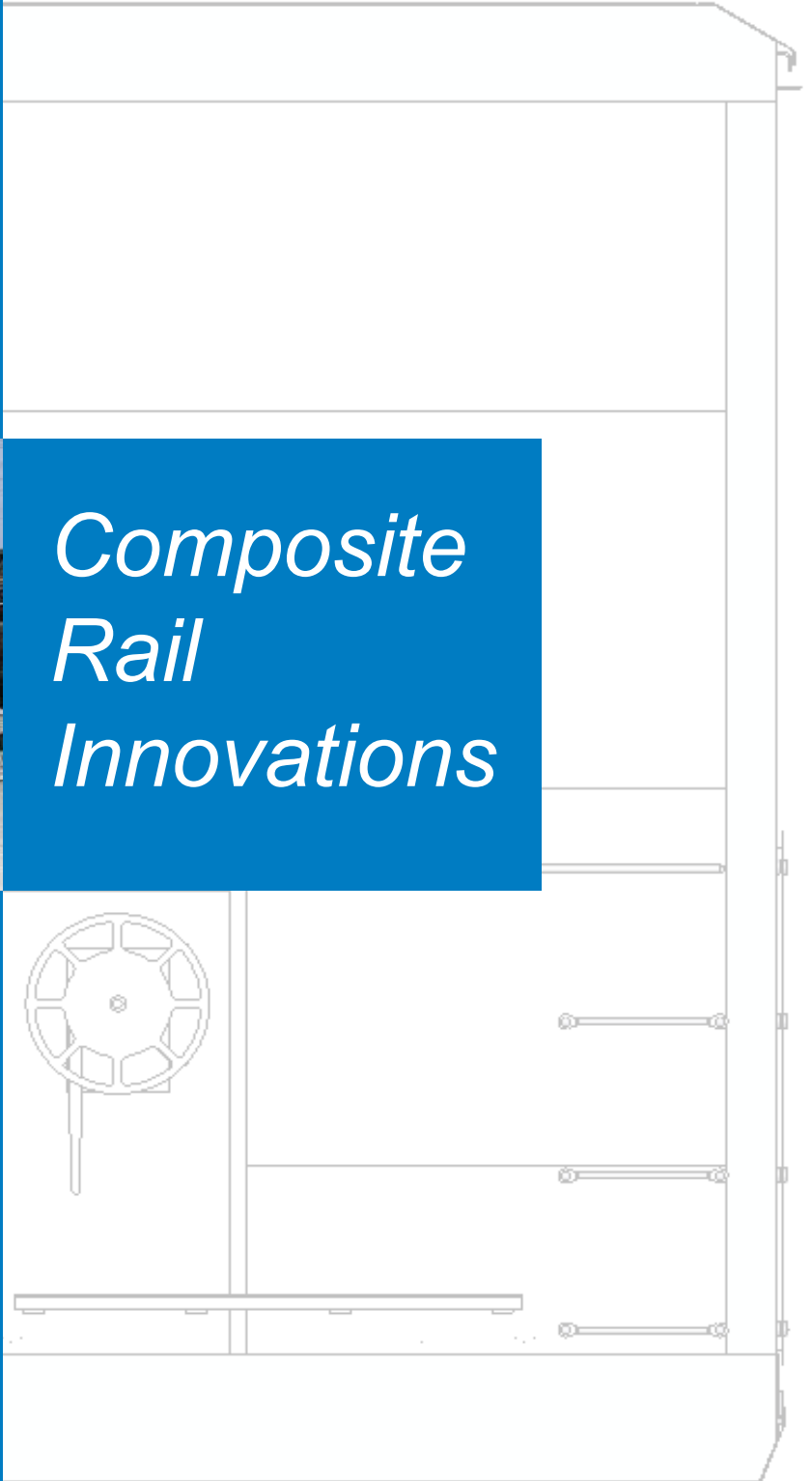

# Composite Rail Innovations



**Martin Marietta Composites**



*Delivering solutions to the rail industry*

# Prefabricated Parts

Martin Marietta Composites is expanding the use of fiber-reinforced polymer (FRP) composites into rail transportation. Composites, made of continuous glass or carbon fabrics in a polymer resin, have long been recognized as having high strength, durability, low weight and corrosion resistance. The advantages of composites bring innovation and efficiency to railcar design.

Composites have many advantages for railcar construction:

- Lower weight components mean lighter weight cars.
- Wood components are eliminated, thus eliminating the problems associated with moisture retention such as warping, rot and mold growth.
- Many composite panels have a higher insulation value (R-Value).
- Production is faster since components are delivered ready to install.

Currently, Martin Marietta Composites offers several products designed for refrigerated railcars, including various prefabricated components and liner materials. Also, new product innovations are always being developed.

As an industry leader in structural composite applications, Martin Marietta Composites is developing and introducing new rail-specific products for refrigerated railcars. These products include:

- Floors
- Wall Panels
- Roofs
- Door Liners
- A & B End Units
- Shelving Units

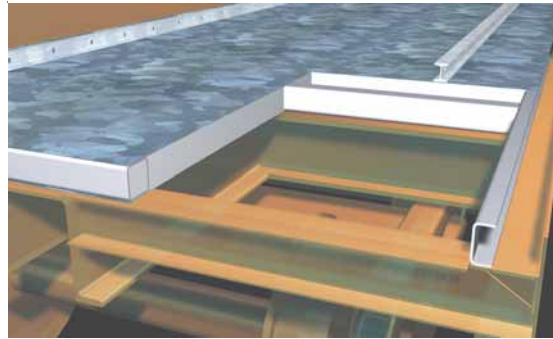

*The flooring system is constructed with sections of FRP, wrapped with stainless steel or aluminum plates and composite material, filled with foam.*

These components feature urethane foam cores with engineered composite wraps, delivering superior insulation, lighter weight and thus a competitive advantage to the railcar owner. All our products are wood free, therefore they will not warp, rot or mold. This system ensures a long service life and maximum protection for valuable refrigerated cargo.



*Our door liner is made from a combination of urethane foam and composite materials.*

Our components are ideal for new railcar construction, since they are delivered ready to install. However, we can also design and manufacture components to retrofit existing cars.

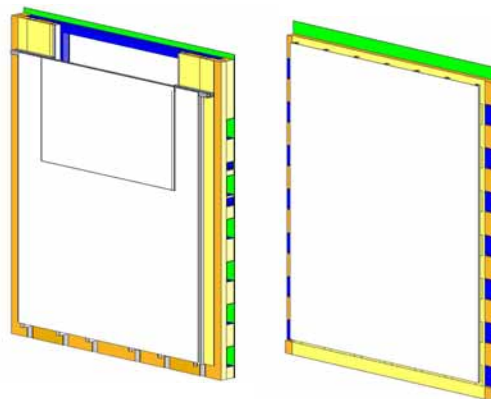

*These "A" and "B" railcar end sections are customized to the manufacturer's railcar design using light weight composites.*

To help you design using our components, Martin Marietta Composites can perform structural analysis using Finite Element Analysis (FEA) and thermal testing to determine insulation values.

# & New Innovations



Our composite panel, which uses the THRESHHOLD™ vacuum insulation technology, provides increased energy savings, increased cargo space and high durability. It ensures the safe delivery of product and reduces the risk of spoilage.



Martin Marietta Composites is currently developing many new high performance composite components to improve R-values and increase durability and performance of conventional railcars.

For higher insulation value, Martin Marietta Composites has developed new uses for vacuum-insulated panels. Vacuum insulation increases R-value and helps eliminate thermal shorts. One inch of Martin Marietta Composites' vacuum-insulated panels is equivalent to over 5 inches of urethane foam — with an R-value of 40. This technology is being used in railcar floors, roofs, walls and doors. TRANSONITE®, the patented 3-D fiber-reinforced sandwich material is also being evaluated for railcar roofs and walls.

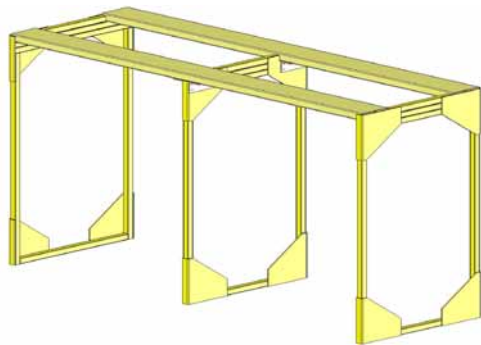

Our composite shelving unit has no wood, thus eliminating warping and splintering.

Our door plug panels are constructed of FRP composite materials utilizing corrugations, high performance vacuum insulation panels and foam insulation. Easily installed in one piece to the inside of a steel boxcar door using adhesives, these door panels ensure maximum thermal protection with a total R-value of 40+.



Martin Marietta Composites is actively pursuing other fiber-reinforced polymer applications for the rail freight market. Other FRP applications include:

- Pallet racks
- Gondola covers
- Boxcar and autorack doors
- Bridge plates for autorack cars

Martin Marietta Composites is dedicated to developing solutions that will benefit your company. Contact us to design and develop your new composite rail components.

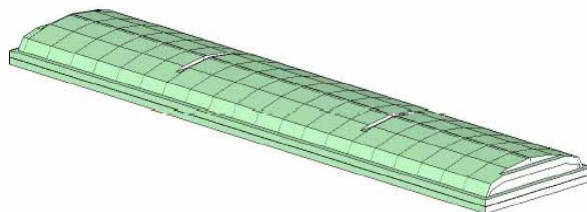

Our Gondola Lids are aerodynamic, durable and conform to the railcar's shape. Because they are also lighter weight and less bulky, the lids are easier to handle.



# High Strength Liners

*Tough &  
Durable*

*Easily  
Cleaned*

*Excellent  
Bonding  
Properties*

*High  
Impact  
Resistance*

*Moisture &  
Chemical  
Resistant*



Martin Marietta Composites provides two primary fiberglass reinforced plastic (FRP) liners for use by the rail Industry:

- Liner Panels - *ArmorTuf*\* and *GatorPlate*\*, lightweight panels used in refrigerated railcars
- Heavy Duty Scuffplate Panels - protective wear band for dry and refrigerated rail cars

## Liner Panel Products

---

### **ARMORTUF**

*ArmorTuf* is a composite panel, specifically designed and formulated for use as liners for railcars. It is light weight with a high impact resistance that can greatly reduce liner panel damage.

*ArmorTuf* is made from fiberglass reinforcement and a specially formulated resin. It features a unique white-pigmented thermoset resin with excellent bonding properties and a heavy-duty glass reinforcement. Together these two components form a composite similar to bullet resistant materials.

Unlike reinforced thermoplastic and other competitive FRP panels, *ArmorTuf's* hard surface is coated with LumaShield protection, providing a very abrasion resistant and easy-to-clean liner panel that will not permanently stain. It has extremely high puncture and impact strength and provides a superb water vapor barrier.

### **GATORPLATE**

*GatorPlate* is a revolutionary new scuff panel that exhibits higher impact and puncture resistance than conventional FRP panels. Unlike wood, it is dimensionally stable with excellent resistance to moisture, mild chemicals, scratches and abrasions. It is easy to install, highly bondable, and easy to keep clean. *GatorPlate* has a high glass content of 38%.

*GatorPlate* is designed and formulated for use in high abuse areas of railcars — dry and refrigerated. It is ideal for applications where an impact resistant wear band is required. Since *GatorPlate* has a more bondable backside and is less sensitive to expansion and contraction than polypropylene, installation costs are lower and field failures are reduced.

# Sizes & Properties

## Scuff Plate Panel Products



### SPI PANELS

Martin Marietta Composites' subpan panels (SPI) are a durable, semi-rigid material made of fiberglass-reinforced plastic. It will not mildew, rot or corrode. With a high strength-to-weight ratio, it has an expansion/contraction value similar to aluminum.

Liner panels can be used for interior sidewalls, ceilings and doors. These panels have been specially designed and formulated for use as a subpan liner to protect the underside of a railcar from moisture penetration.

SPI panels are manufactured using opaque, thermoset polyester resin reinforced with chopped fiberglass strands and are coated with LumaShield protective surface finish.

### FRP Products: Available Sizes

		SPI		
<b>Nominal Thickness</b>	0.145" (3.7mm)	0.050" (1.3mm)	0.06" (1.5mm) 0.075" (1.9mm)	0.07" (1.8mm) 0.085" (2.2mm)
<b>Widths</b>	12"(.3m) 16"(.4m) 24"(.6m) 48"(1.2m)	42" - 96" (1.1m - 2.4m)	up to 104"	up to 104"
<b>Lengths</b>	5'(1.5m) – 350' (107m)	5'-500' (1.5m- 152.4m)	300' 700' coils	300' 700' coils
<b>Wear Finish</b>	Embossed	Embossed	Smooth	Embossed
<b>Nominal Weight</b>	1.12lb/ft <sup>2</sup> (5.47kg/m <sup>2</sup> )	0.32lb/ft <sup>2</sup> (1.55kg/m <sup>2</sup> )	0.46lb/ft <sup>2</sup> (2.25kg/m <sup>2</sup> ) 0.60lb/ft <sup>2</sup> (2.93kg/m <sup>2</sup> )	0.46lb/ft <sup>2</sup> (2.25kg/m <sup>2</sup> ) 0.60lb/ft <sup>2</sup> (2.93kg/m <sup>2</sup> )

*Other lengths and widths available by special request.*



Embossed ArmorTuf



Smooth ArmorTuf



## THRESHHOLD™ provides:

High insulating power  
(R-value)

Increased energy  
savings

Increased usable  
volume

Very long panel life

Exceptional  
dimensional stability

### Introducing THRESHHOLD™

Martin Marietta Composites introduces the THRESHHOLD™ vacuum insulated panel. To have the same insulating power as one inch of THRESHHOLD™ would require approximately 6 times the amount of urethane foam. THRESHHOLD™ provides increased energy savings, increased cargo space and high durability. It ensures the safe delivery of product and reduces the risk of spoilage. It also has exceptional dimensional stability making it ideal for use in tight fitting panel joints.

THRESHHOLD™ consists of a unique core material enclosed in an airtight barrier envelope. The barrier is constructed of a highly durable material that is held to the core through the vacuum. Desiccants are included in the panels to remove any moisture.

### Innovative Composite Wall System

Martin Marietta Composites has developed a composite wall system, which encapsulates the THRESHHOLD™ vacuum insulation panel into a composite shell.

This system was designed for use in areas where there is limited space to inject urethane foam such as the “hat section” of a railcar wall. The composite surrounds and protects the insulation from damage, while providing the advantages of a composite wall inner liner for abuse resistance and cleanliness. There is very little wall thickness in the “hat section” of the wall and consequently a great deal of heat could flow through that area. The use of a thin vacuum insulation panel over this local area greatly improves the thermal performance of this area and consequently the whole wall performance.

### Testing & Evaluation

The THRESHHOLD™ panel has been tested and evaluated using “Hot Box” testing and FEA Analysis. The test results were within 5% of each other and show clearly that the vacuum insulation panel is working. The analysis shows that a vacuum insulation panel covering only 12.7% of the total area and only about ½ inch thick resulted in a 24.7% overall improvement in the thermal performance for the whole sample.

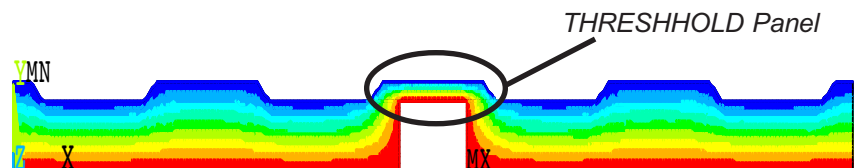

Output from FEA Analysis showing the temperature gradient over the entire composite wall section.

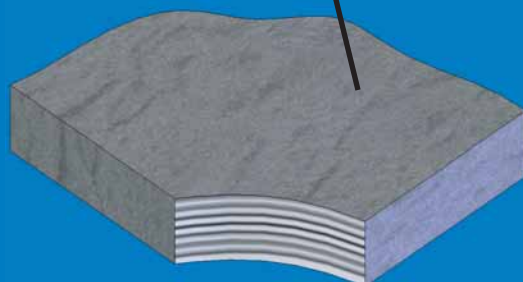
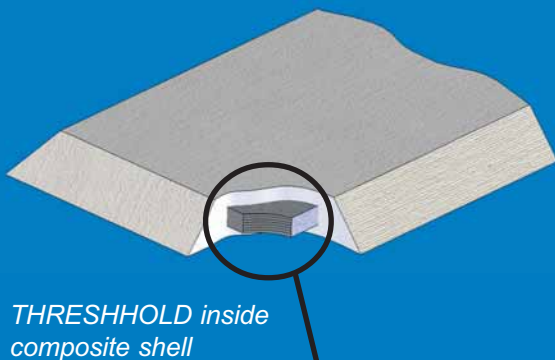

# the Railcar Industry



## Introducing TRANSONITE®

Martin Marietta Composites is offering a multipurpose pultruded structural panel for use in the railcar and transportation industry. The key benefit of this innovative panel system is the use of 3-dimensional fiber insertions to provide a mechanical interlock between the FRP facesheets, virtually eliminating delamination and facesheet disbonding problems. Among this panel's many other benefits is the ability to strategically place the fiber insertions at predetermined locations as indicated by engineering analysis.

This panel has a seemingly endless number of uses, including boxcar walls and roofs, truck sleeper cabs, truck trailer roofs and walls, bridge decks, RV construction, temporary pavements, to mention just a few.

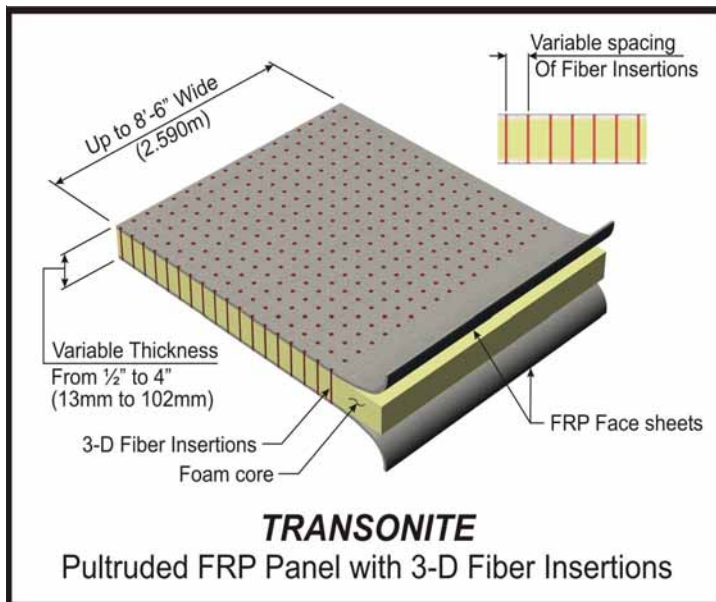

## **TRANSONITE Offers:**

*Performance and damage tolerance unlike any other conventional sandwich technology*

*Tailorable properties to fit specific application requirements*

*Large cut-to-length panels, with or without machined details*



*TRANSONITE Composite Panel*



*TRANSONITE panel with foam removed*

## **How can we meet your need?**

Martin Marietta Composites can provide a custom-designed TRANSONITE panel to meet your specific application. Along with varying skin thickness and fiber insertion densities, panels can also be manufactured to specific dimensions, potentially reducing overall installation costs.

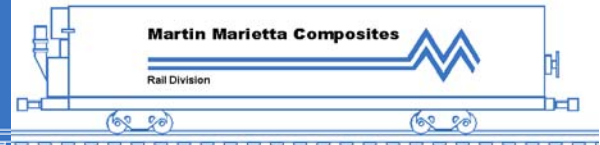

Martin Marietta Composites is a subsidiary of Martin Marietta Materials, Inc. (NYSE:MLM), the nation's second largest producer of construction aggregates.

Headquartered in Raleigh, North Carolina, Martin Marietta Composites develops and markets composite products to the construction, infrastructure and transportation industries.

At Martin Marietta Composites, we are committed to providing support, as well as the expertise to assist our customers in making the transition from traditional materials to composites.



For more information, please contact us at:  
Martin Marietta Composites

Toll free: 1-866-864-6548  
[www.martinmarietta.composites.com](http://www.martinmarietta.composites.com)

*It's not just what we make, it's what we make possible®*